



- Ex.2** Level detector in Zone 0/1
Transducer in Zone 1
- Ex.4** General data,
Rod Series DEX
- Ex.8** Rod Series PEX
- Ex.9** Rod Series NEX
- Ex.10** Magnets and Floats



**Zone 0
and
Zone 1**

Flameproof "d" Transducers and Level detector



Level detector
in Zone 0/1
Transducer
in Zone 1

General data,
Rod
Series DEX

Rod
Series PEX

Rod
Series NEX

Magnets
and
Floats

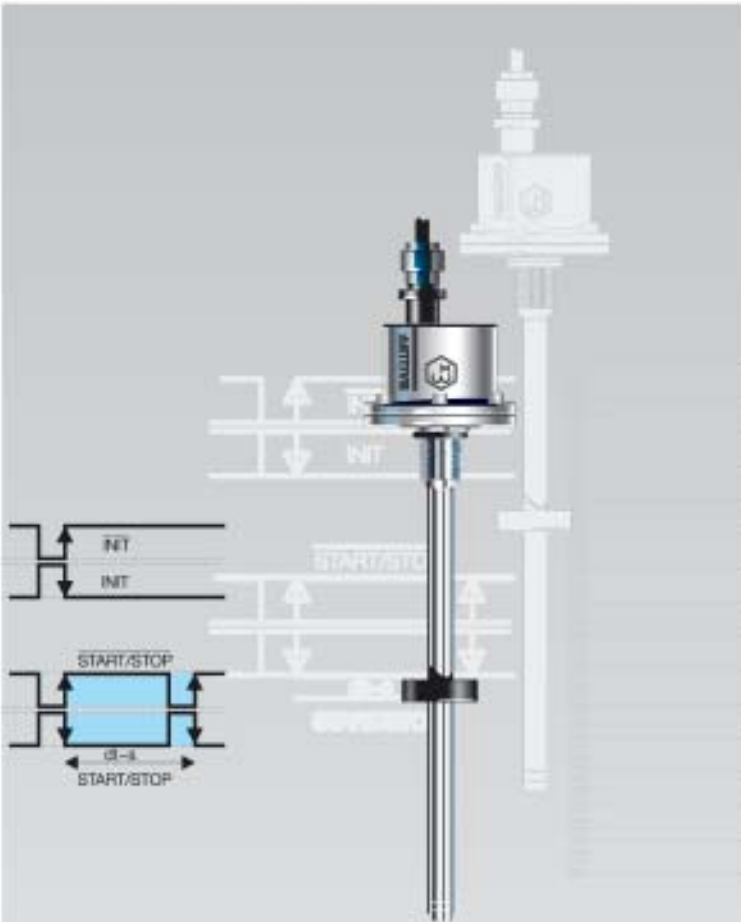

BTL5- 1-M....-B-DEXA- _ _ _

The Rod Version is the safe and reliable approach to level applications in Zone 0. "DEXA". The float is protected against loss by cotter pin. Floats see page **Ex.6**

Applications

- Filling stations
- Tank systems
- Refineries
- Chemical industry
- Pharmaceuticals

Zone 1

Zone 0



Installation

Threaded adapter BTL2-A-KL01-E-00-Ex for adapting the rod length to the height of the tank.

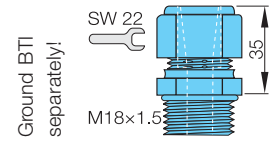

Adapter flange (in development) having 2" thread for installation in a tank.

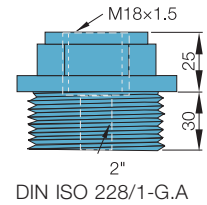

The BTL2-A-DH01-E-32-Ex spacer prevents the floats BTL2-S-4414-...-Ex and BTL2-S-5113-...-Ex from dropping past the measurement range into the damping zone. The sleeve is included with the float.

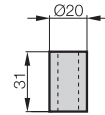

With the union and an additional adapter flange the BTL can be easily installed in any container and adapted to various heights (see illustrations). The thread

penetration depth must ensure safe isolation from zone 0 to zone 1 to DIN EN 50018.



Caution!
Please refer to the instructions in the User Manual before design, installation and commissioning!
www.balluff.com

Zone 1

BTL5-1-M....-B-DEXB-__ Applications

The BTL can be used to sense the position of a hydraulic piston directly and without contact - even up to pressures of 600 bar. The BTL is threaded into the head of the cylinder. The rod section fits into the gun-drilled cylinder rod.

- Position feedback in hydraulic cylinders
- Valve positioning in power plants
- Dosimetry
- Positioning spray guns

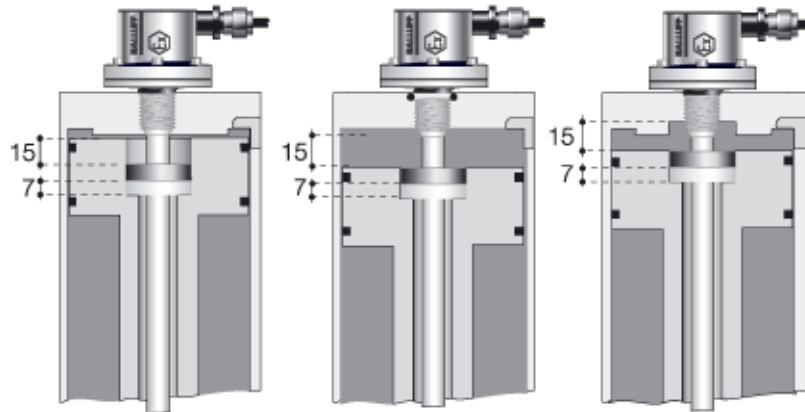

Installation

The BTL Micropulse transducer is provided with an M18x1.5 thread for mounting. We recommend non-magnetizable material for holding the BTL.

If magnetizable materials are used, the installation must be carried out as shown in the drawing below. Sealing is at the flange mounting surface, using the M18x1.5 thread and an included O-ring 15.4 x 2.1.

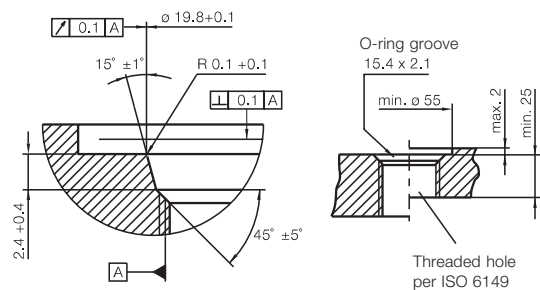

General linear positioning in Zone 1

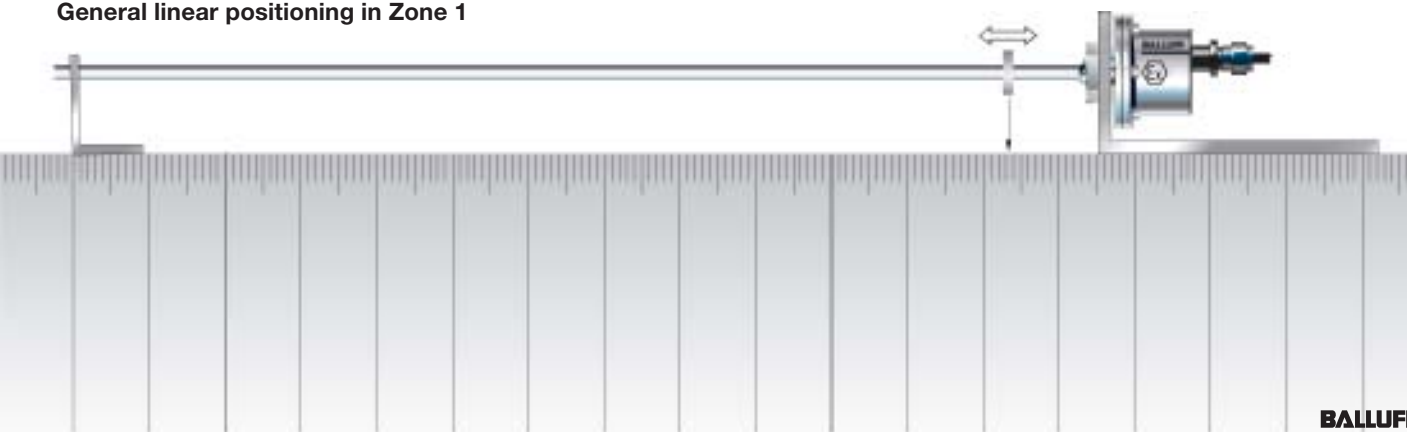

BTL
ex



**Level detector
in Zone 0/1
Transducer
in Zone 1**

General data,
Rod
Series DEX
Rod
Series PEX
Rod
Series NEX
Magnets
and
Floats

Pressure rated to 600 bar, high repeatability, non-contact, rugged

The BTL Micropulse transducer is the rugged position feedback system for use under extreme ambient conditions measuring between 25 and 4000 mm.

Ex rating "d" Flameproof enclosure

Transducers designated **EEx d IIB + H₂ T6** meet the requirements for electrical devices in explosive atmospheres per EN 50014; 1997 and EN 50018; 1994.

When using you must follow the relevant safety regulations, such as:

- Explosion protection guidelines (EX-RL)
- Constructing electrical equipment in potentially explosive areas (VDE 0165)
- Protection type "d" cable gland (EN 50018)

For this product with designation **EEx dIIB + H₂ T6** the Declaration of Conformity **PTB No. Ex-00.E.1004X** has been issued.

- **Flameproof "d"**
- **EEx d IIB + H₂ T6**
- **Stainless**



ATEX

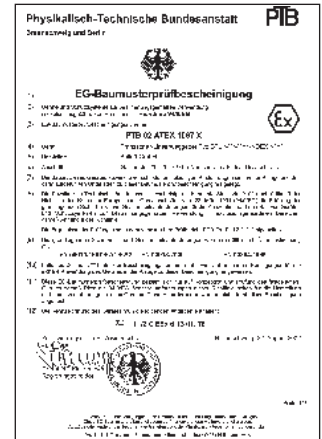
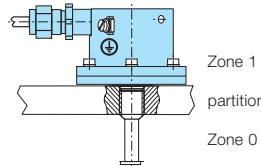

Analog interface no null or end point trim possible, see page **K.H.7**

Ordering example:

BTL5- -M - -DEX -

	Output signal	Standard nominal strokes [mm]	Housing	Rod end	Connection type
A11	0...10 V and 10...0 V, rising and falling	0025, 0050, 0075, 0100, 0125, 0150, 0175, 0200, 0225, 0250,	B J	A Float stop B Short stop	Axial cable only with housing B KA02 PUR cable 2 m KA05 PUR cable 5 m KA10 PUR cable 10 m KA15 PUR cable 15 m
E10	4...20 mA or 20...4 mA, rising	0400, 0425, 0450, 0475, 0500, 0550, 0600, 0650, 0700, 0750,			Radial cable K02 PUR cable 2 m K05 PUR cable 5 m K10 PUR cable 10 m K15 PUR cable 15 m
E17	4...20 mA or 20...4 mA, falling	0800, 0850, 0900, 0950, 1000, 1100, 1200, 1300, 1400, 1500,			
C10	0...10 mA and 10...0 mA, rising	1600, 1700, 1800, 1900, 2000, 2250, 2500, 2750, 3000, 3250,			
C17	0...10 mA and 10...0 mA, falling	3500, 3750, 3850, 4000 or in 5 mm increments on request			
G11	-10...10 V and 10...-10V, rising and falling				

Digital pulse interface see page **K.H.9**

Ordering example:

BTL5- 1-M - -B-DEX -

	Interface	Standard nominal strokes [mm]	Rod end	Connection type
P	Pulse interface P	see above	A Float stop B Short stop	see above
I	Pulse interface I	analog interface DEX		analog interface DEX

SSI interface see page **K.H.11**

Ordering example:

BTL5-S1 -M - -B-DEX -

	Coding	System resolution	Standard nominal strokes [mm]	Rod end	Connection type
0	Binary code rising (24 bits)	1 1 µm	see above	A float stop B short stop	see above
1	Gray code rising (24 bits)	2 5 µm	analog interface DEX		analog interface DEX
6	Binary code rising (25 bits)	3 10 µm	max. 4000 mm		
7	Gray code rising (25 bits)	4 20 µm 5 40 µm			

Series

BTL5 Compact rod, IS

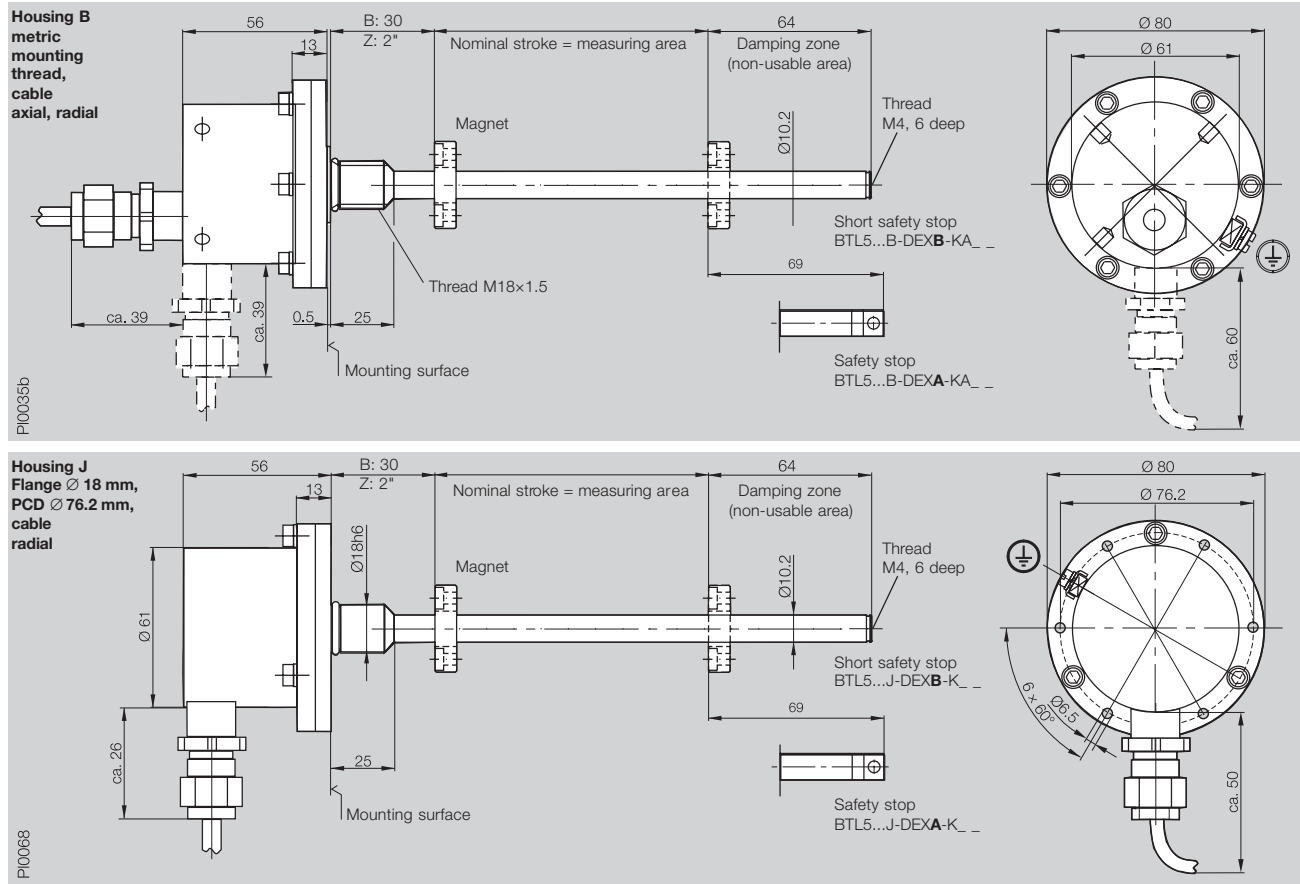

Ordering code	BTL5- 1-M _ _ _ -DEX -
Shock load	100 g/6 ms per IEC 60068-2-27 and 100 g/2 ms per IEC 60068-2-29
Vibration	12 g, 10...2000 Hz per IEC 60068-2-6
Polarity reversal protected	yes
Overvoltage protection	Transzorb protection diodes
Dielectric constant	500 V (GND to housing)
Enclosure rating per IEC 60529	IP 67
Housing material	Stainless steel 1.4305
Flange and tube material	Tube stainless 1.4571, flange 1.4571 or 1.4429 or 1.4404
Housing attachment	Thread M18x1.5, 3/4"-16 UNF on request
Connection type	Cable connection
EMC testing:	
RF emission	EN 55011 Group 1, Class A
Static electricity (ESD)	IEC 61000-4-2 Severity Level 3
Electromagnetic fields (RFI)	IEC 61000-4-3 Severity Level 3
Fast transients (BURST)	IEC 61000-4-4 Severity Level 4
Line-borne noise, induced by high-frequency fields	IEC 61000-4-6 Severity Level 3

- Included:
- Transducer
(select your interface from page **K.H.6**)
 - User's Guide

Please order separately:
Magnets page **B.16**
Floats see page **Ex.10**

Caution!
Please refer to the instructions in the **User Manual before design, installation and commissioning!**
www.balluff.com

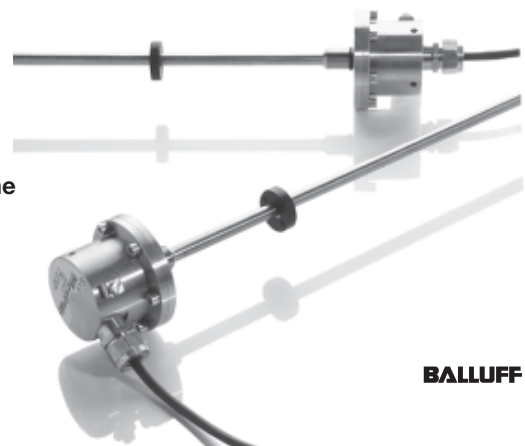

Level detector in Zone 0/1
Transducer in Zone 1
General data, Rod Series DEX
Rod Series PEX
Rod Series NEX
Magnets and Floats

Flameproof enclosure

Analog interface, see page **B.5**

Ordering example:

BTL5- -M - -J-DEXC-TA12

Output signal	Standard nominal strokes [mm]	Connection type
A11 0...10 V and 10...0 V, rising and falling	0025, 0050, 0075, 0100, 0125, 0150, 0175, 0200, 0225, 0250, 0275, 0300, 0325, 0350,	TA12 = 1/2"-14 NPT Internal thread
E10 4...20 mA	0375, 0400, 0425, 0450, 0475, 0500, 0550,	
E17 20...4 mA, falling	0600, 0650, 0700, 0750, 0800, 0850, 0900,	
C10 0...20 mA, rising	0950, 1000, 1100, 1200, 1300, 1400, 1500,	
C17 20...0 mA, falling	1600, 1700, 1800, 1900, 2000, 2250, 2500,	
G11 -10...10 V and 10...-10 V, rising and falling	2750, 3000, 3250, 3500, 3750, 3850, 4000, 4250, 4500 or in 5 mm steps on request.	

Programming tool for nullpoint and endpoint **BTL5-A-EH03**

Digital pulse interface, see page **B.7**

Ordering example:

BTL5- 1-M - -J-DEXC-TA12

Interface	Standard nominal strokes [mm]	Connection type
P Pulse interface P	see above	TA12 = 1/2"-14 NPT Internal thread
I Pulse interface I	Analog interface J-DEXC	

SSI interface, see page **B.9**

Ordering example:

BTL5-S1 -M - -J-DEXC-TA12

Coding	System resolution	Standard nominal strokes [mm]	Connection type
0 Binary code rising (24 bits)	1 1 µm	see above	TA12 = 1/2"-14 NPT Internal thread
1 Gray code rising (24 bits)	2 5 µm	analog interface	
6 Binary code rising (25 bits)	3 10 µm	J-DEXC,	
7 Gray code rising (25 bits)	4 20 µm	max. 4000 mm	
	5 40 µm		

CANopen interface, see page **B.11**

Ordering example:

BTL5-H1 -M - -J-DEXC-TA12

Software configuration	Baud rate	Standard nominal strokes [mm]	Connection type
1 1 × Position and 1 × Velocity	0 1 MBaud	see above	TA12 = 1/2"-14 NPT Internal thread
2 2 × Position and 2 × Velocity	1 800 kBaud	analog interface	
	2 500 kBaud	J-DEXC,	
	3 250 kBaud	max. 4000 mm	
	4 125 kBaud		
	5 100 kBaud		
	6 50 kBaud		
	7 20 kBaud		
	8 10 kBaud		

PROFIBUS-DP interface, see page **B.13**

Ordering example:

BTL5-T1 0-M - -J-DEXC-TA12

Software configuration	Standard nominal strokes [mm]	Connection type
1 1 magnet	see above	TA12 = 1/2"-14 NPT Internal thread
2 2 magnets	analog interface J-DEXC, max. 4000 mm	

Caution!
Please refer to the instructions in the **User Manual** before design, installation and commissioning!
www.balluff.com



CE 0518 II 1/2
GD



APPROVED

Class I, Division I,
Groups A, B, C and D
Class II/III, Division I,
Groups E, F, and G
T6 Ta = 65°C,
T5 Ta = 80°C
Type 4X/6P



Class I Zone 1
AEx d IIC
T6 Ta = 65°C,
T5 Ta = 80°C



EEx d IIC T6
Ta = 65°C,
T5 Ta = 80°C
IP 68
SIRA 04 ATEX 1290

Series	BTL5_-M_-_-J-DEXC-TA12

Housing J-DEXC
Flange \varnothing 18 mm, PCD \varnothing 76.2 mm

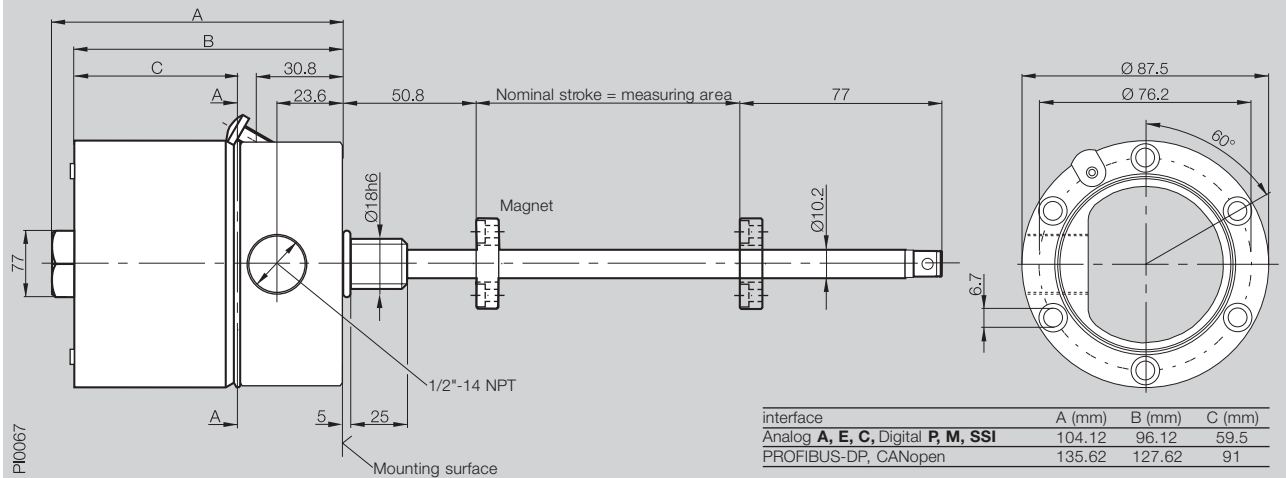

Ordering code	BTL5_-M_-_-J-DEXC-TA12
Shock load	100 g/6 ms to IEC 60068 2-27
Vibration	12 g, 10...2000 Hz per IEC 60068-2-6
Operating temperature	-20...+80 °C
Storage temperature	-40...+100 °C
Index of Protection	IP 68
Housing material	Stainless steel Nitronics 60
Tube	1.4571 stainless
Pressure rating	600 bar max.
Connection type	Screw terminals
Cable entry	Ex cable gland BTL-A-AD09-M-00EX
EMC testing:	
RF emission	EN 55011 Group 1, Class A
Static electricity (ESD)	IEC 61000-4-2 Severity Level 3
Electromagnetic fields (RFI)	IEC 61000-4-3 Severity Level 3
Fast transients (BURST)	IEC 61000-4-4 Severity Level 4
Line-borne noise, induced by high-frequency fields	IEC 61000-4-6 Severity Level 3

- Included:
- Transducer (select your interface from page **K.H.6**)
 - Short user's guide

Please order separately:
Magnets page **B.16**
Floats see page **Ex.10**

Cable gland
1/2" - 14 NPT to M20 metric
BTL-A-AD09-M-00EX

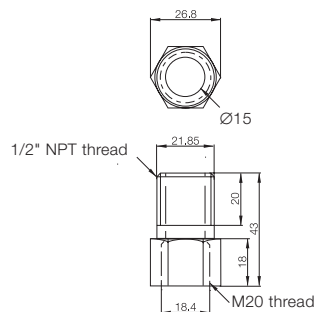

CSA/AE
AEx de Class I, Zone I, Groups I & IIC
Class I, Division I & 2, Groups A, B, C, D
Class II & III, Groups E, F, G



CENELEC
SIRA 00A TEX1094
EEx de I & IIC
I M2, II 2 GD

The Micropulse transducer J-DEXC has been specially developed for use in Ex areas. The important demands of the oil and gas industry for high reliability and ease of servicing are combined in the J-DEXC system. J-DEXC comprises a robust flameproof Ex housing and an electronics module that is easily accessed and exchanged for servicing. Spare electronics modules can be ordered from Balluff Service Dept.

- Applications:
- hydraulic or pneumatically actuated valves
 - Clutch travel monitoring for compressors
 - Level monitoring
 - Level control
 - Position sensing for hydraulic cylinders in Ex areas



Level detector in Zone 0/1
Transducer in Zone 1

General data, Rod Series DEX
Rod Series PEX
Rod Series NEX
Magnets and Floats

Dust protection zone 22 II 3 D T 90°C X

Dust protection zone 22

Devices of these categories are intended for use in areas where it is not expected that swirling dust will create an explosive atmosphere. The probability is extremely small. Even were it to occur, it would be only for a short space of time.

A manufacturer's certificate is provided, confirming that the transducer code is

II 3 D T 90°C X

satisfying the requirements for electrical equipment for use in areas with inflammable dust

EN 50014: 1997 and
EN 50281-1-1: 1998.



Digital pulse interface, see page **B.7**

Ordering example:

BTL5-P1-M - -PEX-KA02

Standard nominal strokes [mm]	Housing	Connection type
0025, 0050, 0075, 0100, 0125, 0150, 0175, 0200, 0225, 0250, 0275, 0300, 0325, 0350, 0375, 0400, 0425, 0450, 0475, 0500, 0550, 0600, 0650, 0700, 0750, 0800, 0850, 0900, 0950, 1000, 1100, 1200, 1300, 1400, 1500, 1600, 1700, 1800, 1900, 2000, 2250, 2500, 2750, 3000, 3250, 3500, 3750, 3850, 4000, 4250, 4500, 4750, 5000, 5250, 5500 or in 5 mm steps on request.	B M18x1.5 Z 3/4" 16UNF	PUR cable 2 m

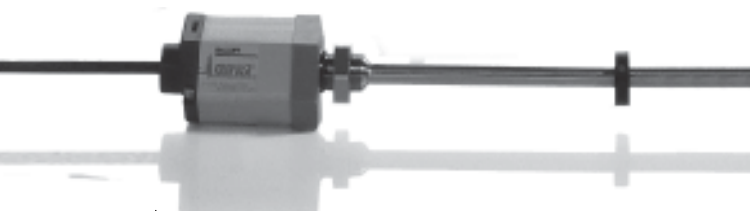



Flameproof type "n" for zone 2

Flameproof type "n" code "EEx n"

Devices of these categories are intended for use in areas where it is not expected that an explosive atmosphere will occur. The probability is extremely small. Even were it to occur, it would be only for a short space of time.

A manufacturer's certificate is provided, confirming that the product satisfies the requirements for electrical equipment for use in areas with explosion hazards to EN 50021: 1999.

Several methods of flameproofing are combined under the designation.

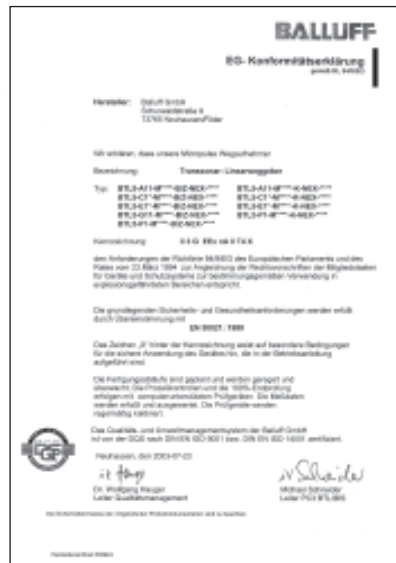

Housing K

see page **K.H.3/7/9**

Ordering example:

BTL5- -M -K-NEX-

	Output signal	Standard nominal strokes [mm]
A11	10...0 V and 0...10 V	0025, 0050, 0075, 0100, 0125,
C10	0...20 mA	0150, 0175, 0200, 0225, 0250,
C17	20...0 mA	0275, 0300, 0325, 0350, 0375,
E10	4...20 mA	0400, 0425, 0450, 0475, 0500,
E17	20...4 mA	0550, 0600, 0650, 0700, 0750,
P1	pulse interface P	0800, 0850, 0900, 0950, 1000,
		1100, 1200, 1300, 1400, 1500,
		1600, 1700, 1800, 1900, 2000,
		2250, 2500, 2750, 3000, 3250,
		3500, 3750, 3850, 4000, 4250,
		4500 or in 5 mm steps on request.

Connection type

SR32 with connector plug
K05 PUR cable 5 m

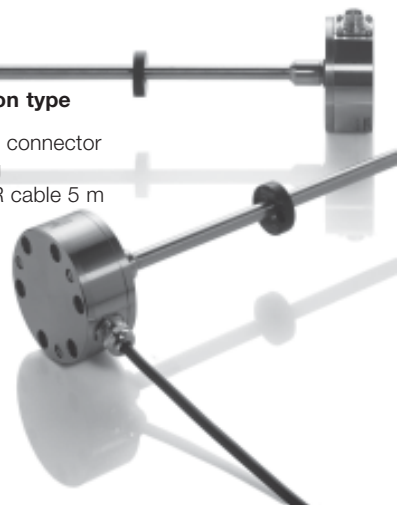

Rod Series

see page **B.3/5/7**

Ordering example:

BTL5- -M -NEX-

	Output signal	Standard nominal strokes [mm]
A11	10...0 V and 0...10 V	0025, 0050, 0075, 0100, 0125,
C10	0...20 mA	0150, 0175, 0200, 0225, 0250,
C17	20...0 mA	0275, 0300, 0325, 0350, 0375,
E10	4...20 mA	0400, 0425, 0450, 0475, 0500,
E17	20...4 mA	0550, 0600, 0650, 0700, 0750,
G11	-10...10 V and 10...-10 V	0800, 0850, 0900, 0950, 1000,
P1	pulse interface P	1100, 1200, 1300, 1400, 1500,
		1600, 1700, 1800, 1900, 2000,
		2250, 2500, 2750, 3000, 3250,
		3500, 3750, 3850, 4000, 4250,
		4500 or in 5 mm steps on request.

Housing

B M18x1.5
Z 3/4" 16UNF

Connection type

S 32 with connector plug
KA05 PUR cable 5 m

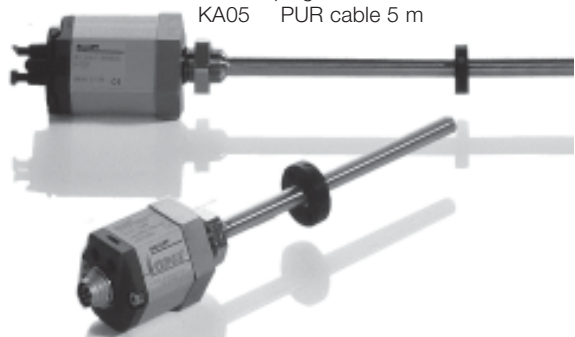

Level detector in Zone 0/1
Transducer in Zone 1

General data, Rod Series DEX

Rod Series PEX

Rod Series NEX

Magnets and Floats

Floats (Zone 0)

BTL2-S-4414-4Z-Ex
Cylindrical float Zone 0
permitted up to specific
gravity $\rho \geq 0.7 \text{ g/cm}^3$

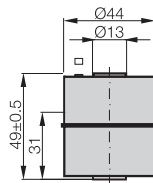

Orientation:
Raised dimple on upper
side of float

BTL2-S-4414-4Z01-Ex
Cylindrical float Zone 0
Float density $\rho = 0.85 \text{ g/cm}^3$
for liquid interface sensing

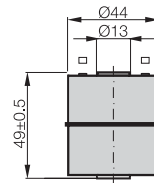

Orientation:
2 raised dimples on upper
side of float

Interface
A second float can be added
to measure the position
of the interface between two
liquids, such as oil and
condensed water.
Recommended:
BTL2-S-4414-4Z01-Ex.

BTL2-A-DH01-E-32-Ex
Spacer sleeve for the float:
BTL2-S-4414-4Z-Ex
BTL2-S-4414-4Z01-Ex
BTL2-S-5113-4K-Ex
The sleeve is included.

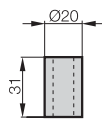

BTL2-S-5113-4K-Ex
Ball float Zone 0
permitted up to specific
gravity $\rho \geq 0.7 \text{ g/cm}^3$

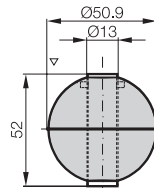

Orientation:
Raised dimple on upper
side of float

BTL2-S-6216-8P-Ex
Parabolic float
usable up to $\rho \geq 0.6 \text{ g/cm}^3$

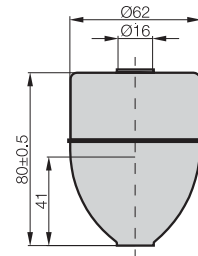

Float model	Immersion depths assuming	
	$\rho = 1 \text{ g/cm}^3 (\text{H}_2\text{O})$	$\rho = 0.7 \text{ g/cm}^3 (\text{H}_2\text{O})$
BTL2-S-6216-8P-Ex	$s_s \sim 41 \text{ mm}$	$s_s \sim 57 \text{ mm}$
BTL2-S-5113-4K-Ex	$s_s \sim 26 \text{ mm}$	$s_s \sim 40 \text{ mm}$
BTL2-S-4414-4Z-Ex	$s_s \sim 30 \text{ mm}$	$s_s \sim 39 \text{ mm}$
BTL2-S-4414-4Z01-Ex	$s_s \sim 45 \text{ mm}$	submerges

see page **B.17**

Adapter flange

BTL2-A-AD01-E-00-Ex 2"/M18×1.5 see page **Ex.2**

Thread adapter

BTL2-A-KL01-E-00-Ex M18×1.5 see page **Ex.2**

**Magnets (Zone 1)
for installing in
hydraulic cylinder**

See page **B.16**

**Processor cards,
digital displays**

See starting page **BTA.3/5**